

7882IRD Series

Professional DVBS/S/S2X MPEG-2/H.264 SD/HD Integrated Receiver Decoders

The 7882IRD Series is the basis of a professional platform for receiving, demodulating and decoding digital DVB-S/S2/S2X satellite signals. With a compact, modular form-factor the 7882IRD represents one of the highest density and most flexible solutions in the industry. The 7882IRD-S2X may be mounted in the Evertz 7800 series of enclosures, providing a high-density, modular solution. Options for an innovative removable front control panel and 1RU chassis also allow the IRD to be packaged in the traditional IRD form factor, while maintaining all of the benefits of modularity.

Applications include signal reception for broadcasters, cable, DTH and IPTV providers, or any other small to large head-end operators who need to receive and utilize or re-distribute satellite content. The 7882IRD series provides ASI and IP outputs, ideal for turnaround, transcoding, monitoring or other applications where the received signal remains in the compressed domain. For baseband output, the 7882IRD2 utilizes an advanced decoder with support for both MPEG-2 and H.264/AVC, SD or HD encoded signals, optionally up to 4:2:2 10-bit.

In addition to a quad-RF input, the 7882IRD also provides inputs for IP and ASI signals, making it a future-proof, universal reception platform for signals delivered over satellite, fiber and other network media. Monitoring parameters such as EsNo ratio, RF power, BER and packet errors present a convenient solution for broadcasters and cable companies who wish to not only receive, but also remotely monitor signal quality. Also, these parameters as well as Full monitoring and control of the IRD are relayed over SNMP, for convenient remote access using Evertz own VistaLINK® PRO SNMP monitoring and control package. Additionally, low-speed data support is provided for in-band control.

For applications requiring decryption, the IRD provides a slot for installation of a customer supplied conditional access module. DVB-CI compliant conditional access modules and formats are supported.

► Features & Benefits

- Modular design, allowing flexible configurations along with easy system reconfiguration and service
- May be mounted in the 7800FR series frames in high-density applications
- May be mounted in the 7801FR and fitted with the 7801CP control panel, yielding a 1RU 7882IRD with removable front control panel and optional redundant power supplies, all of which are hot-swappable and may be serviced without any de-cabling required
- Up to two units may be mounted in the 7801FR and used with the 7801CP, providing a dual-IRD solution in 1RU
- Future-proof with upgrade paths to support future modulation and encoding technologies
- Standard support for advanced modulation schemes, including DVB-S2 with 16APSK, 32APSK and 64APSK
- Optional DVB-S2X Modulation support
- Standard support for advanced transport stream processing including service filtering and output bitrate control
- Long frames and Short frames
- CCM, VCM and ACM
- SCPC and MCPC support
- Automatic detection and configuration of modulation type, filter roll-off, symbol rate, pilot presence (on/off) and frame length
- Supports optional on-board Input auto-failover between various inputs including RF/ASI or IP inputs
- Flexible decoding of SD and HD as standard
- Support for encoding profiles from distribution to contribution grade, including H.264 in 4:2:0 8-bit and optional 4:2:2 10-bit formats "software upgradable", along with legacy MPEG-2
- Available DVB-CI slot for conditional access modules
- Available BISS and BISS-E decryption
- Flexible mid-stage access to compressed domain signals, including ASI and optional IP output along with ASI and optional IP inputs
- Straight pass through or PID filtering/remapping of compressed stream outputs
- Standard Dolby pass through and decode of Dolby AC-3 and MPEG-2 Layer 1 audio
- Optional decoding of Dolby-E, Plus and AAC
- Eight AES outputs
- Optional Audio Video Monitoring (AVM option) for audio mute and video freeze and black detection
- Optional SCTE 105/34 translation
- Control through web-browser or SNMP using third-party application or Evertz's own VistaLINK SNMP control and monitoring software
- Ability to store ten preset configurations
- Event log support with exporting capabilities are supported on VLPRO and built-in Control Port for direct control and management of the IRD

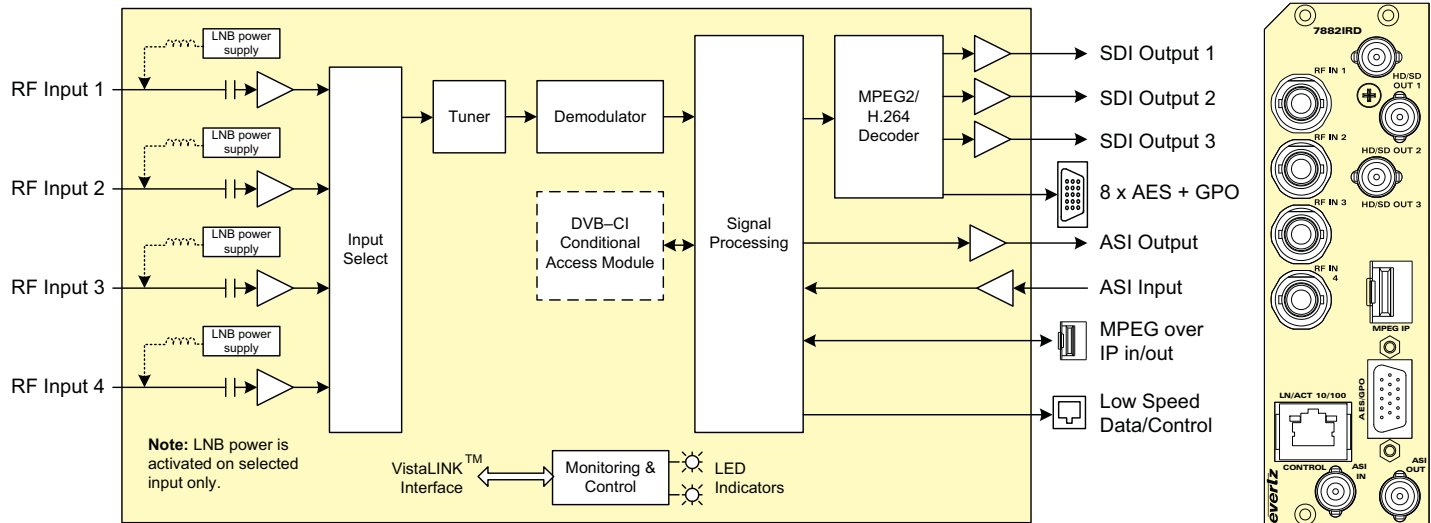

7882IRD Series

Professional DVBS/S/S2X MPEG-2/H.264 SD/HD Integrated Receiver Decoders

Specifications

<p>RF Input: Number: 4 Connector: 75Ω F-Type (Optional BNC connector) Frequency: 950–2150 MHz Power: –20 to –65dBm Voltage: 13/18V DC, off (selectable) Max Current: 400mA Protection: Short circuit, overload Local oscillator: 1000 to 35000 MHz to be used for C-Band & Ku-Band Input Return Loss: 15 dB Min. Noise Figure: 9dB Max. AFC Tuning Range: ±67 MHz using search range IF Filter Bandwidth: adjusted from 6 MHz to 50 MHz in 1-MHz steps</p> <p>Modulation Support: Symbol Rate: Up to: QPSK, 8PSK, 16APSK: 64 Msps 32APSK: 51 Msps 64APSK: 43 Msps</p> <p>Coding Rates: FECFRAME (normal) 64 800 (bits) DVB-S QPSK: 1/2, 2/3, 3/4, 5/6, 7/8 DVB-S2 QPSK: 1/4, 1/3, 2/5, 1/2, 3/5, 2/3, 3/4, 4/5, 5/6, 8/9, 9/10 DVB-S2 8PSK: 3/5, 2/3, 3/4, 5/6, 8/9, 9/10 DVB-S2 16APSK: 2/3, 3/4, 4/5, 5/6, 8/9, 9/10 DVB-S2 32APSK: 3/4, 4/5, 5/6, 8/9, 9/10 DVB-S2x QPSK: 1/4, 1/3, 2/5, 1/2, 3/5, 2/3, 3/4, 4/5, 5/6, 8/9, 9/10, 13/45, 9/20, 11/20 DVB-S2x 8PSK: 3/5, 2/3, 3/4, 5/6, 8/9, 9/10, 23/36, 25/36, 13/18 DVB-S2x 8APSK-L: 5/9, 26/45 DVB-S2x 16APSK: 2/3, 3/4, 4/5, 5/6, 8/9, 9/10 (S2-MODCODs), 26/45, 3/5, 28/45, 23/36, 25/36, 13/18, 7/9, 77/90 DVB-S2x 16APSK-L: 5/9, 8/15, 1/2, 3/5, 2/3 DVB-S2x 32APSK: 3/4, 4/5, 5/6, 8/9, 9/10, 32/45, 11/15, 7/9 DVB-S2x 32APSK-L: 2/3 DVB-S2x 64APSK: 11/15, 7/9, 4/5, 5/6 DVB-S2x 64APSK-L: 32/45</p>	<p>FECFRAME (short) 16 200 (bits) DVB-S2x QPSK: 1/4, 1/3, 2/5, 1/2, 3/5, 2/3, 3/4, 4/5, 5/6, 8/9, 9/10, 11/45, 4/15, 14/45, 7/15, 8/15, 32/45 DVB-S2x 8PSK: 3/5, 2/3, 3/4, 5/6, 8/9, 7/15, 8/15, 26/45, 32/45 DVB-S2x 16APSK: 2/3, 3/4, 4/5, 5/6, 8/9, 7/15, 8/15, 26/45, 3/5, 32/45 DVB-S2x 32APSK-L: 2/3, 32/45</p> <p>ASI Input: Number: 1 Type: ASI per DVB TR101–891 Connector: 75Ω BNC</p> <p>ASI Output: Number: 1 Type: ASI per DVB TR101–891 Connector: 75Ω BNC</p> <p>MPEG over IP Input/Output (+IP Option): Number: 1 Type: SMPTE 2022–1, –2 Connector: One GbE Data Port using SFP (SFP ordered separately)</p> <p>Conditional Access Support: One DVB–CI slot</p> <p>Baseband Video Outputs: Number: 3 (third BNC is configurable to be ASI or SDI output) Connector: 75Ω BNC Type: SDI (SMPTE ST 259), HD–SDI (SMPTE ST 292–1)</p> <p>AES Audio Outputs: Number: 8 PIDS (16 channels of embedded PCM) Connector: BNC breakout from DB–15 Type: Unbalanced AES Standard: AES3 (aka AES/EBU) as an AES output standard Compression Format: MP1L2 and Dolby digital AC–3 upto 3/2L Passthrough: PCM, Dolby Digital, Dolby–E Optional: Dolby–E decode and AAC–LC</p>	<p>Ancillary Data: Embedding of: Audio pass through Closed caption/Teletext SCTE35 to 104 (+SCTE104 option) AFD/WSS Time code</p> <p>High Quality Down Convert (+HDC option): Down conversion: SMPTE 292 to SMPTE 259 Aspect ratio: Fixed Scalar or follow AFD</p> <p>Low Speed Data: Number: 1 Type: De-encapsulation from control data PID Connector: RJ–45, 10/100/1000</p> <p>Frame Sync (+FSE Option): • Sync 1080i/59.94, 1080i/50, 720p/59.94, 720p/50, 525i/59.94, 625i/50 • Video Delay between 3 lines & 1 frame + 3 Lines • Programmable output phase with respect to reference input • Reference input via common 7800FR/7801FR frame reference connector</p> <p>Control: • SNMP over Ethernet via frame controller • Web browser • Low speed control data over Ethernet output derived from data PID • 4 x GPO following commercial trigger</p> <p>Electrical: Power: <46 Watts Voltage: 12VDC Temperature: 0–50°C</p> <p>Physical: Number of slots: 2</p>
---	---	--

Ordering Information

7882IRD–S2X DVBS/S2/S2X IRD, up to 64APSK, quad L–Band input, single demodulator, single DVB–CI conditional access slot, ASI input and output, MPEG–2/H.264 SD/HD decode (4:2:0 8–bit)

Rear Plate Suffix
+3RU 3RU Rear Plate for use with 7800FR or 7801FR Multiframe
+B75 75Ω BNC connector for RF input

Ordering Options
+FSE Integrated frame synchronizer
+42210B 4:2:2 (MPEG–2/H.264) and 10–bit (H.264) decode
+DD Dolby–E decode
+AAC AAC decode
+IP IP midstage in/output (SFP sold separately)
+SCTE104–1 SCTE 35/104 translation
+DBISS BISS and BISS–E decryption

3RU Enclosures
7800FR 3RU Multiframe which holds up to 15 single slot modules

1RU Enclosure and Front Control Panel
Note: 7801FC is required for 1RU IRD configuration

SFPTR–RJ45–SGM–AV 1x 10/100/1000 Ethernet Copper RJ–45 for IP Streaming Output

7801FR 1RU Multiframe which holds up to 4 single or 2 dual slot modules
+781PS Redundant power supply (optional)
7801FC Frame controller module
+IRDCP Removable front control panel for 7801FR populated with 7882IRD(s)

7882DM–FK–S2K License to enable DVB–S2X (Broadcast and DSNG profiles) demodulation standards